

INSTRUCTION MANUAL  
FOR  
Combo Electrotherapy Device

**R-C101I**

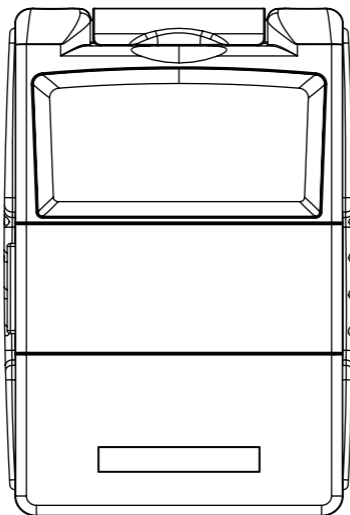

Shenzhen Roundwhale Technology Co., Ltd.  
This manual is valid for the R-C101I Stimulator

Be sure to read this instruction manual before operation and  
keep it where safe.

This user manual is published by Shenzhen Roundwhale  
Technology Co., Ltd.

Shenzhen Roundwhale Technology Co., Ltd. does not guarantee its contents and reserves the right to improve and amend it at any time without prior notice. However, Amendments will be published in a new edition of this manual.

All Rights Reserved.

R-C101I Rev. V1.1© 2024, printed on Aug. 8, 2024.

**Declaration of conformity:**

Shenzhen Roundwhale Technology Co., Ltd. declares that the device complies with following normative documents:

IEC60601-1, IEC60601-1-2, IEC60601-1-11, IEC60601-2-10, IEC62304,

ISO10993-5, ISO10993-10, ISO10993-1, ISO10993-23, ISO14971.

## TABLE OF CONTENTS

1. FOREWORD	4
2. SAFETY INFORMATION	6
3. GETTING TO KNOW YOUR DEVICE	11
4. SPECIFICATION	13
5. OPERATING INSTRUCTION	17
6. INSTRUCTIONS FOR USE	23
7. CLEANING AND MAINTENANCE	31
8. TROUBLESHOOTING	32
9. STORAGE	34
10. DISPOSAL	35
11. ELECTROMAGNETIC COMPATIBILITY (EMC) TABLES	35
12. NORMALIZED SYMBOLS	41
13. WARRANTY	42

# **1. FOREWORD**

## **1.1 Introduction**

The device R-C101I is a dual channel output Combo Electrotherapy Device. Before using, please read all the instructions in this user manual carefully and keep it safe for future use.

The Combo Electrotherapy Device belongs to the group of electrical stimulation systems. It has one basic functions—TENS (Transcutaneous Electrical Nerve Stimulation).

Function of the TENS stimulator: The device has 5 programs (B (Burst), N (Normal), M (Modulation) SD1 (Strength Duration) and SD2 (Strength Duration)) applies electric currents in the low-frequency range for therapy. Each program controls the generated electric impulses, their intensity, frequency and pulse width.

Based on simulating the body's natural pulses, the mechanism of electrical stimulation equipment is to create electric impulses that are transcutaneous transmitted to nerves or muscle fibers through the electrode. The intensity of the dual channel can be adjusted independently and applied individually to one body part. This dual channel device can be used with four pieces of electrodes, which allow you to stimulate one muscle groups simultaneously with a wide selection of standard programs. The electrical pulse is firstly transmitted to the tissue, then it affects the transmission of stimulation in nerves as well as muscle tissues in the

body parts.

## **1.2 Medical background**

### **1.2.1 ABOUT PAIN**

Pain is an important signal in the human body warning system. It reminds us that something is wrong, without which, abnormal conditions may go undetected, causing damage or injury to vital parts of our bodies. Even though pain is a necessary warning signal of trauma or malfunction in the body, nature may have gone too far in its design.

Aside from its function in diagnosis, long-lasting persistent pain serves useless purpose.

Pain does not occur until encoded message travels to the brain where it is decoded, analyzed, and reacted to, from the injured area along the small nerves leading to the spinal cord. There the message is transmitted to different nerves that travel up the spinal cord to the brain. Then the pain message is interpreted, referred to and pain is felt.

### **1.2.2 WHAT IS TENS ?**

TENS (Transcutaneous Electrical Nerve Stimulation) is effective in relief of pain. It is daily used and clinically proven by physiotherapists, caregivers and top athletes around the world. High-frequency TENS currents activates the pain-inhibiting mechanisms of the nervous system. Electrical impulses from electrodes, placed on the skin over or near the pain area, stimulate the nerves to block the pain signals to the brain, causing the pain go unperceived. Low-frequency TENS currents facilitate the release of endorphins, the body's natural painkillers.

## **2. SAFETY INFORMATION**

### **2.1 Intended use**

#### **Intended purpose**

The device is designed to be used for temporary relief of pain, including the acute and chronic pain relief.

#### **Target population**

The device using the object (patient) must be 18 years or older of adults.

#### **Intended user**

Medical staff or lay persons.

#### **Intended condition**

Intended for use in the home, hospital and health care facilities.

#### **Indications**

It is used for temporary relief of pain associated with sore and aching muscles in the neck, shoulder, back, joint, hip, hand, abdomen, upper extremities (arm) and lower extremities (leg) due to strain from exercise or normal household work activities.

### **2.2 Important Safety Precautions and Warnings**



It is important that you read all the warnings and precautions included in this manual because they are intended to keep you safe, prevent risk of injury and avoid a situation that could result in damage to the device.

#### **SAFETY SYMBOLS USED IN THIS MANUAL**

##### **2.2.1 Contraindication**

- 1) Do not use this device if you have a cardiac pacemaker, implanted defibrillator, or other implanted metallic or electronic device. Such use could cause electric shock, burns, electrical interference, or death.
- 2) The device should not be used when cancerous lesions or other lesions are present in the treatment area.



- 3) Stimulation should not be applied over open wounds or rashes, or over swollen, red, infected, or inflamed areas or skin eruptions (e.g. phlebitis, thrombophlebitis, varicose veins, arteriosclerosis obliterans etc.).
- 4) Electrode placements must be avoided that apply current to the carotid sinus region (anterior neck) or transcerebrally (through the head). 
- 5) Apprehensive patients-usage of Electrical stimulation requires patient cooperation, hence the procedure shouldn't be attempted in patients with a communication handicap or a mental disability.
- 6) Patients with cerebrovascular problems-patients with a history of aneurysm, stroke and transient ischaemia shouldn't be treated using electrical stimulation, as it stimulates peripheral blood flow which can be fatal in such cases.
- 7) Epileptic patients-Electrical stimulation "pulses" have the potential to trigger a seizure.
- 8) Acute pain cases/pain of unknown etiology-usage of TENS in undiagnosed cases may hinder in the diagnosis.
- 9) Do not use in pregnancy, especially in the first trimester.

### 2.2.2 WARNING

- 1) If you have had medical or physical treatment for your pain, consult with your physician before use.
- 2) If your pain is not subdued, which becomes more than mild, or lasts for more than five days, stop using the device and consult with your physician.
- 3) Do not apply stimulation over your neck because this could cause severe muscle spasms resulting in closure of your airway, difficulty in breathing, or adverse effects on heart rhythm or blood pressure.
- 4) Do not apply stimulation across your chest because the introduction of electrical current into the chest may cause rhythm disturbances to your heart, which could be lethal.

- 5) Do not apply stimulation over, or in proximity to, cancerous lesions.
- 6) Do not apply stimulation in the presence of electronic monitoring equipment (e.g., cardiac monitors, ECG alarms), which may not operate properly when electrical stimulation device is in use.
- 7) Do not apply stimulation when in bath or shower.
- 8) Do not apply stimulation while sleeping.
- 9) Do not apply stimulation while driving, operating machinery, or during any activity when electrical stimulation can put you at risk of injury.
- 10) Apply stimulation only to normal, intact, clean, healthy skin.
- 11) The long-term effects of electrical stimulation are unknown. Electrical stimulation device cannot replace drugs.
- 12) Stimulation should not take place while the user is connected to high-frequency surgical equipment, which may cause burn injuries on the skin under the electrodes, as well as problems with the stimulator.
- 13) Do not use the stimulator in the vicinity of shortwave or microwave therapy equipment, since this may affect the output power of the stimulator.
- 14) Never use it near the cardiac area. Stimulation electrodes should never be placed anywhere on the front of the thorax (marked by ribs and breastbone), but above all not on the two large pectoral muscles. There it can increase the risk of ventricular fibrillation and lead to cardiac arrest.
- 15) Never use it on the eye, head and face area.
- 16) Never use it near the genitals.
- 17) Never use it on the areas of the skin which lack normal sensation.



- 18) Keep electrodes separate during treatment. It could result in improper stimulation or skin burns if electrodes are in contact with each other.
- 19) Keep the stimulator out of reach of children.
- 20) Consult your doctor if you are in any doubt whatsoever.
- 21) Discontinue it and do not increase the intensity level if you feel discomfort during use.

### 2.2.3 Precautions

- 1) TENS is not effective for pain of central origin including headache.
- 2) TENS is not a substitute for pain medications and other pain management therapies.
- 3) TENS is a symptomatic treatment and, as such, suppresses the sensation of pain that would otherwise serve as a protective mechanism.
- 4) Effectiveness is highly dependent upon patient selection by a practitioner qualified in the management of pain patients.
- 5) Since the effects of stimulation of the brain are unknown, stimulation should not be applied across your head, and electrodes should not be placed on opposite sides of your head.
- 6) The safety of electrical stimulation during pregnancy has not been established.
- 7) You may experience skin irritation or hypersensitivity due to the electrical stimulation or electrical conductive medium (silica gel).
- 8) If you have suspected or diagnosed heart disease or epilepsy, you should follow precautions recommended by your physician.
- 9) Caution if you have a tendency to bleed internally, e.g. following an injury of fracture.

- 10) Consult with your physician prior to use the device after a recent surgical procedure, because stimulation may disrupt the healing process.
- 11) Caution if stimulation is intended to be applied over the menstruation or pregnant uterus.
- 12) For single patient use only.
- 13) This stimulator should not be used by patients who is non compliant and emotionally disturbed including whom with dementia or low IQ.
- 14) The instruction of use is listed and should be obeyed; any improper use may be dangerous.
- 15) Rare cases of skin irritation may occur at the site of the electrode placement following long-term application.
- 16) Do not use this device in the presence of other equipment which sends electrical pulses to your body.
- 17) Do not use sharp objects such as a pencil or ballpoint tip to operate the buttons on the control panel.
- 18) Check the electrode connections before each use.
- 19) Electrical stimulator should be used only with the electrodes recommended for use by the manufacturer.
- 20) When output of device more than 10mA or 10 V, the intensity of Channel will filcker.
- 21) Users should consult a healthcare professional before using the device.
- 22) The user shall report any serious incident related to the device to the manufacturer and the competent authorities of the Member States establishing the user and / or the patient.

#### **2.2.4 Adverse Reactions**

- 1) Possible skin irritation or electrode burn under the electrodes may occur.
- 2) Possible allergic skin reaction to tape or gel may occur.
- 3) If symptoms of tachycardia and extrasystolia (rapid heartbeat or extra stimulation) appear during treatment, stop the treatment and seek medical attention immediately.

- 4) If the stimulation makes you uncomfortable, reduce the stimulation Intensity to a comfortable level and contact your physician if problems continue.

### 3. GETTING TO KNOW YOUR DEVICE

#### 3.1 Package includes

No.	Description	QTY
1	Combo Electrotherapy Device	1pc
2	Electrode pad (40mm×40mm)	4pcs
3	Electrode wires	2pcs
4	9 Volt Battery	1pc
5	User manual	1pc

#### 3.2 LCD display

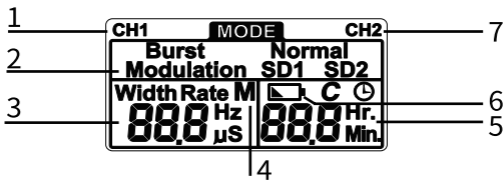

No.	Function description	No.	Function description
1	Icon of Channel 1	5	Treatment time
2	Treatment mode	6	Low battery icon
3	Pulse width and Pulse rate	7	Icon of Channel 2
4	Memory icon		

### 3.3 Device illustration

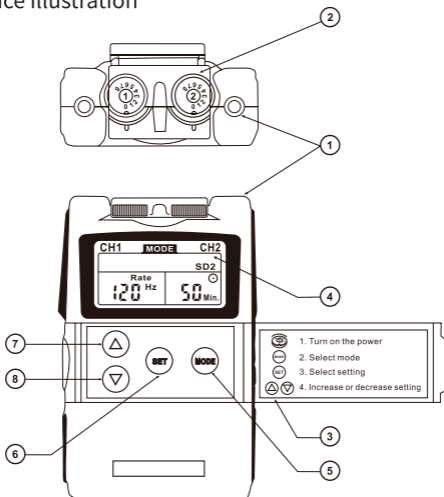

FRONT

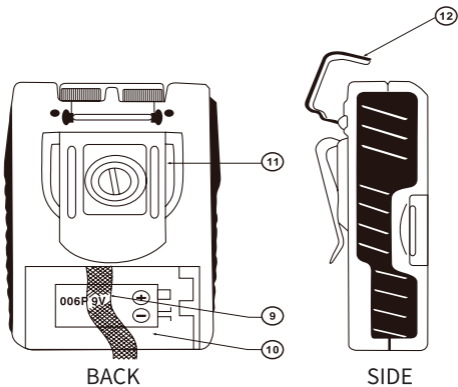

BACK

SIDE

No.	Description
1	Lead Connector
2	Intensity Control (ON/OFF Switch)
3	Panel Cover
4	Liquid Crystal Display
5	Mode Control
6	Set Control
7	Increment Control
8	Decrement Control
9	Battery Strip
10	Battery Case
11	Belt Clip
12	Case Protector

## **4. SPECIFICATION**

### **4.1 Technical information**

Device name	Combo Electrotherapy Device
Model/type	R-C101I
Power sources	One 9 volt battery
Output channel	Dual channel
Waveform	Bi-phase square-wave pulse
Output current	0-50V (Load:500 ohm)
Output intensity	adjustable
Treatment mode:	TENS mode
Operating condition	5° C to 40° C with a relative humidity of 15%-93%, atmospheric pressure from 700 hPa to 1060 hPa
Storage condition	-10° C to 55° C with a relative humidity of 10%-95%, atmospheric pressure from 700 hPa to 1060 hPa
Dimension	10.1 cm (L) x 6.1 cm (W) x 2.45 cm (H)
Weight	111 grams with battery
Classification	BF type applied part, internal power equipment
Size of electrodes pad	40x40mm, square

Output precision	$\pm 20\%$ error is allowed for all the output parameters
P.W. (Pulse Width)	Adjustable, from 50 to 300 $\mu\text{s}$ , 10 $\mu\text{s}$ /step
P.R. (Pulse Rate)	Adjustable, from 2 to 150 Hz, 1 Hz/step
Time	Adjustable, from 1 to 60 minutes or continuous.
Modes	B (Burst), N (Normal), M (Modulation), SD1 (Strength Duration) and SD2 .
Burst Mode	Burst rate: adjustable, 0.5 - 5 Hz, Pulse with adjustable, 50~300 $\mu\text{s}$ Frequency fixed = 100 Hz
Normal Mode	The pulse rate and pulse width are adjustable. It generates continuous stimulation based on the setting value.
Modulation Mode	Modulation mode is a combination of pulse rate and pulse width modulation. The pulse rate and width are automatically varied in a cycle pattern. The pulse width is decreased by 50% from its original setting in the 0.5 second, then the pulse rate is decreased by 50% from its original setting in the 0.5 second. Total cycle time is 1 second. In this mode, pulse rate (2~150Hz) and pulse width (50-300 $\mu\text{s}$ ) are fully adjustable.
SD1 Mode	The SD1(Strength-Duration) mode consists of automatic modulation intensity and pulse width in 40% range. The intensity is always increasing while the pulse width is decreasing and vice versa. The intensity is decreased by 40% while the pulse width is increased by 40% in 5 seconds. In the next 5 seconds, the intensity is increased by 40% while the pulse width is decreased by 40%. Total cycle time is 10 seconds. Pulse rate (2~150Hz) and pulse width (50-300 $\mu\text{s}$ ) are fully adjustable.

SD2 Mode	The SD2 (Strength-Duration) mode consists of automatic modulation intensity and pulse width in 70% range. The intensity and pulse width in 70% range. The intensity is always increasing while the pulse width is decreasing and vice versa. The intensity is decreased by 70% while the pulse width is increasing by 70% in 5 seconds. In the next 5 seconds, the intensity is increased by 70% while the pulse width is decreased by 70%. Total cycle time is 10 seconds. Pulse rate (2~150Hz) and pulse width (50-300 $\mu$ s) are fully adjustable.
Patient Compliance Meter	This unit can store 60 sets of operation records. Total recorded time is 999 hours.
Low Battery Indication	A low battery indicator will show up on the LCD when the battery is low.
Device service life	5 years
Electrode pads shelf life	3 years
Software version	V1.0

The waveforms of the 5 stimulation modes are as follows.

1. Burst

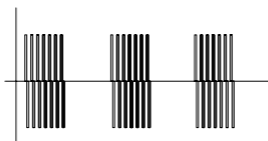

2. Normal

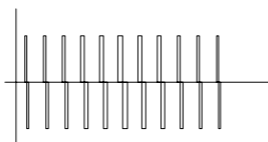

### 3. Modulation

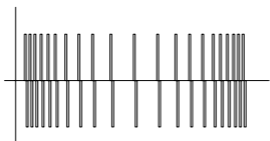

### 4. SD1 (Strength-Duration)

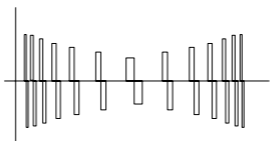

### 5. SD2 (Strength-Duration)

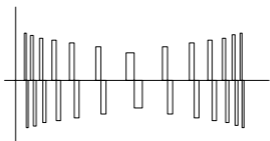

## 5. OPERATING INSTRUCTION

### 5.1 Battery

#### 5.1.1 Check/ replace batteries

Open the battery cover, insert one 9 volt battery into the battery compartment. Make sure you are installing the batteries properly. Be sure to place the batteries according to the markings of positive terminal (+) and negative terminal (-) in the battery compartment of device.

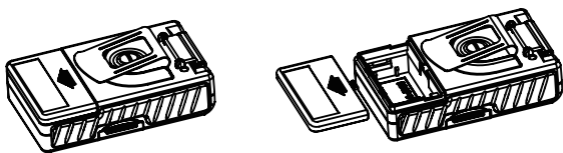

#### 5.1.2 Disposal of battery



Spent batteries do not belong to the household waste. Dispose of the battery following the current regulations. As a consumer, you have legal obligation to return spent battery to the Recycle Bin.

1. If a battery was swallowed accidentally, please seek medical assistance immediately!
2. In case of battery leakage, please avoid contacting with the battery through skin, eyes and mucus membranes. Once it occurs, please wash the contacted part with plenty of clean water and contact your doctor immediately.
3. Battery cannot be dismantled, thrown into fire or short-circuited.
4. Protect battery from excess heat; Take the battery out of the product if they are spent or you don't use it for a long

time. This can prevent device from damage due to the battery leakage.

5. Replace all of the batteries simultaneously!

6. Always replace the device with the same type battery.

## 5.2 Connect electrode pads to electrode wires

Insert the electrode wires connector into electrode connector. Make sure they are properly connected to ensure the good performance. Please refer to the picture.

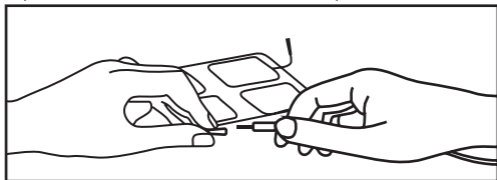

### Caution

Always use the electrode pads which comply with the requirements of the IEC/EN60601-1, ISO10993-1/-5/-10 and IEC/EN60601-1-2, as well as CE and FDA 510(K) regulation.

## 5.3 Connect electrode wires to device

Before proceeding to this step, ensure that the device is completely switched OFF.

Hold the insulated portion of the electrode wire connector, and insert the plug into the receptacle on the top of the main device.

Ensure the electrode wires are inserted correctly. The device has two output receptacles controlled by Channel 1 and Channel 2 at the top of the unit. You may choose to use one channel with one pair of electrode wires or both channels with two pairs of electrode wires. Using both channels

gives the user the advantage of stimulating two different areas at the same time.

### **Caution**

Do not insert the plug of the electrode wires into any AC power supply socket.

## 5.4 Electrode

### 5.4.1 Electrode options

The electrodes should be routinely replaced when they start to lose their adhesiveness. If you are unsure of your electrode adhesive properties, please order new replacement electrodes. Replacing electrodes should be re-ordered under the advice of your physician or the device manufacturer to ensure proper quality. Follow application procedures outlined on electrode packing when using the new replacement electrodes to maintain optimal stimulation and to prevent skin irritation.

### 5.4.2 Place electrodes on skin

Place the electrode on the body part in need of treatment, according to the instruction of this user manual. Please make the skin clean before use and ensure the skin and electrode connect well.

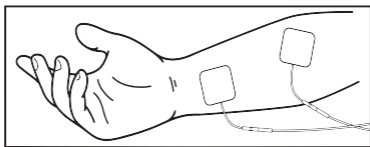



## **Caution**

1. Always remove the electrodes from the skin with a moderate pull in order to avoid injury in the event of highly sensitive skin.
2. Before applying the self-adhesive electrodes, it is recommended to wash and degrease the skin, and then dry it.
3. Do not turn on the device when the self-adhesive electrodes are not positioned on the body.
4. To remove or move the electrodes, switch off the device or the appropriate channel first in order to avoid unwanted irritation.
5. It is recommended that, at minimum, 1.5"x 1.5" self-adhesive square electrodes are used at the treatment area.
6. Never remove the self-adhesive electrodes from the skin while the device is still on.

### **5.4.3 Electrode placement**

R-C101I is a kind of OTC stimulator, suitable for home use. You only have to use according to the user manual, place the electrode on the position where you feel pain. Conduct exercise, treatment and adjustment based on your own feeling.

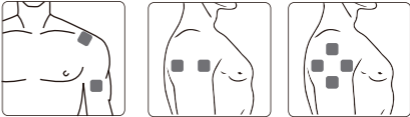
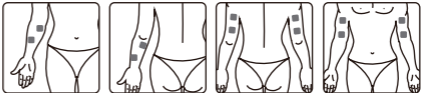
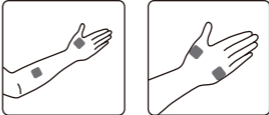
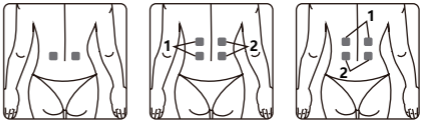
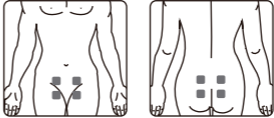
## Position of electrode placement under TENS programs

Neck				
Shoulder				
Arm				
Hand				
Back				
Abdomen				
Hip				

Leg				
Foot				
Joint (knee)				
Joint (elbow)				
Joint (ankle)				
Joint (wrist)				

## 6. INSTRUCTIONS FOR USE

### 6.1 Power On/Off Switch and Intensity Controls:

If both controls are in the off-position, the device is switched off. By turning the controls clockwise, the appropriate channel is switched on and the indicator of power (CH1 or CH2) will reveal on the LCD. The current strength of the impulses transmitted to the electrodes increases further when the control is turned clockwise.

To reduce the amount of current or power off, turn the control counter clockwise to the required setting or off position.

The controls are protected by a cover to prevent inadvertent change of intensity.

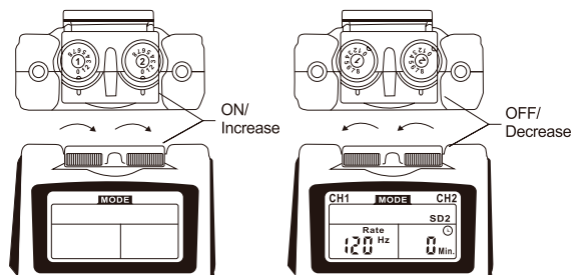

### 6.2 Lead Connector

The connection of the electrodes is performed with the two lead wires. The device must be turned off before connecting cables. Both intensity controls must be in the off position. The electrodes should be placed firmly on the skin.

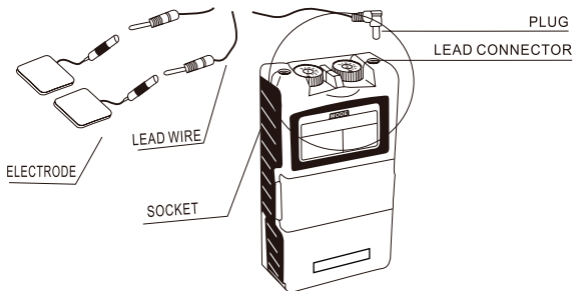

### 6.3 Mode Control **MODE**

There are 5 modes available - Burst, Normal, Modulation , SD1, SD2 . The therapeutic mode can be selected by pressing the "MODE" control.

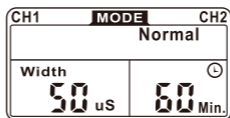

### 6.4 Configuration Control **SET**

By pressing the "SET" button , you can enter the value of configuration to perform. You can begin to set the value by pressing the controls of " increase" and " decrease" when the value flashes .

### 6.5 Increment Control **△**

This button controls the increase of settings . When you press this button, the parameter increase.

## 6.6 Decrement Control

This button controls the decrease of parameter. When pressing this button, the parameter will decrease.

## 6.7 Timer

The unit: has a timer of 1- 60 minutes and Continuous. It can be adjusted by pressing the "Set" and "Increment" or "Decrement" controls. The treatment time will countdown automatically one minute by one minute. Its output will be shut off when time is up.

## 6.8 Low Battery Indicator

A low battery indicator will show up on the liquid crystal display when the battery needs to be replaced. The unit may continue to operate for a few more hours depending on the settings intensity level.

## 6.9 Steps to Set a New Program

### a. Turn on the intensity

After the electrodes are placed firmly on skin and the lead wires are plugged in the socket of device, turn the on/off control clockwise. The liquid crystal display will be light up.

### b. Select a Mode

Select a mode by pressing the "MODE" control. The mode you select will show up on the top of liquid crystal display. There are 5 adjustable modes of your option, including -Burst, Normal, Modulation, SD1 and SD2.

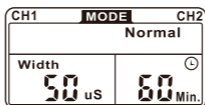

### c. Set Pulse Width

Pulse Width is adjustable from 50  $\mu\text{s}$  to 300  $\mu\text{s}$ . Press "SET" control to enter this menu, then press "Increment" or "Decrement" to adjust the setting. If no instructions regarding the pulse width are given in therapy, set the control to the suggested 70-120  $\mu\text{s}$  setting.

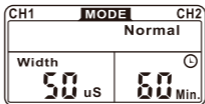

### d. Set Pulse Rate

Pulse rate is adjustable 2Hz to 150Hz. Press "SET" control to enter this menu, then press "Increment" or "Decrement" to adjust the setting. Unless otherwise instructed, turn the pulse rate control to the 70-120 Hz setting.

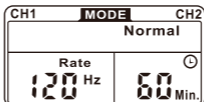

### e. Set Timer

Press "SET" to enter this setting. The treatment time is adjustable from 1 to 60 minutes or Continue. Press "Increment" or "Decrement" control to adjust setting. Your settings will be stored in this unit eternally unless they are adjusted again.

You can set the timer to "Continuous" mode by pressing the "increment" control when it shows 60 minutes.

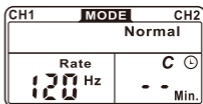
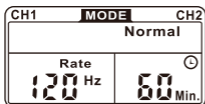

Continuous

## 6.10 Patient Compliance Meter

This unit can store 60 sets of operation records. Total treatment time up to 999 hours can be stored.

### Check and Delete Individual Records

Press "Mode" control and turn on the power simultaneously. The LCD will show the number of records and operation time. Press the "Increment" and "Decrement" button to check each record. To delete a record, press "SET" control for 3 seconds.

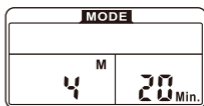
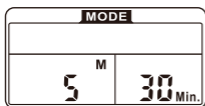

### Check and Delete Accumulative Record

At the individual records menu, press "Mode" control to switch to accumulative record menu. Press the "Set" control first, then press the "Mode" control simultaneously for 3 seconds and all of the records will be deleted followed by a beeper sound.

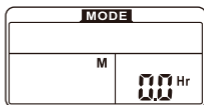
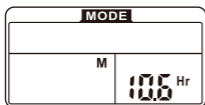

## 6.11 Check/Replace the Battery:

Over time, in order to ensure the functional safety of TENS, changing the battery is necessary.

1. Make sure that both intensity controls are switched to off position.

2. Slide the battery compartment cover and open.
3. Remove the battery from the compartment.
4. Insert the battery into the compartment.  
Note the polarity indicated on the battery and in the compartment.
5. Replace the battery compartment cover and press to close.

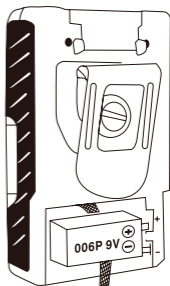

### Notice of batteries:

1. Batteries may be fatal if swallowed. Therefore, keep the batteries and the product out of the reach of children. If a battery is swallowed, go to a hospital immediately.
2. If there's battery leakage, avoid contact with skin, eyes and mucus membranes. Rinse the affected spots with plenty of clear water immediately and contact a physician right away.
3. Batteries must not be charged, dismantled, thrown into fire or short-circuited.
4. Protect batteries from excess heat. Take the batteries out of the device if they are spent or in case that you will no longer use the them. This prevents damage caused by leaking batteries.

### 6.12 Usage of electrode pads

1. The electrode may only be connected with the Combo Electrotherapy Device. Make sure that the device is turned off when attaching or removing the electrode pads.

2. If you want to reposition the electrode during the application, turn the device off first.
3. The usage of electrode may lead to skin irritations. If you experience such skin irritations, e.g. redness, blistering or itching, discontinue using them. Do not use the Combo Electrotherapy Device permanently on the same body part, as this may also lead to skin irritations.
4. Electrode pads are private and intended for single person use. Please avoid using them by different persons.
5. The electrode must connect entirely to the skin surface to prevent hot spots, which may lead to skin burns.
6. Do not use the electrode pads for more than 15 times, as connection between the electrodes and the skin deteriorates over time.
7. The adhesive force of the electrodes depends on the skin properties, storage condition, and the number of applications. If your electrode pads no longer fully stick to the skin's surface, replace them with new ones. Stick the electrode pads back onto the protective foil after use and store them in the storage bag to prevent them from drying out. This retains the adhesive force for a longer period.
8. Do not use detergent to clean the electrode pads before and after use to avoid damaging the adhesion of the electrode pads.
9. The electrode pads must always be touched with clean hands, it is recommended to replace the electrode pads if they become dirty.

**Caution:**

- 1) Before applying the electrode, it is recommended for users to wash and degrease the skin, and then dry it.
- 2) Never remove the electrode from the skin while the device is still on.

3) Only use the electrode pads provided by the manufacturer. Usage of other companies' products could result in injuries to the user.

### **6.13 Where do I attach electrode pads?**

1. Each person reacts differently to electric nerve stimulation. Therefore, the placement of the electrodes may deviate from the standard. If application is not successful, contact your physician to find out which placement techniques are best for you.
2. Do not use any adhesive electrodes with a size smaller than those the original manufacturer attached. Otherwise the current density may be too high and cause injuries.
3. The size of the adhesive pads may not be changed, e.g. by clipping off parts of them.
4. Make sure that the region radiating the pain is enclosed by the electrodes. In case of painful muscle groups, attach the electrodes in such a way that the affected muscles are also enclosed by the electrodes.

### **Usage advice for TENS:**

If you don't feel any discomfort during the treatment, we advise you to use the device until the session ends. Normally, the pain relief occurs after 5~10mins treatment;

If you feel discomfort during treatment, you can either pause the session or decrease the intensity of the output.

Normally, we advise 1~2 treatments per day and one week as a period of treatment;

After a period of treatment, if the pain relief is not achieved or the pain gets even worse, please consult your doctor.

## **7. CLEANING AND MAINTENANCE**

Fully comply with the following necessary daily maintenance requirements to make sure the device is intact and guarantee its long-term performance and safety.

### **7.1 Cleaning and care for the device**

7.1.1 Pull the electrodes out of the stimulator, clean the device with a soft, slightly damp cloth. In case of heavier dirt build-up, you may also apply a mild detergent.

7.1.2 Do not expose the Combo Electrotherapy Device to moisture or dampness. And do not hold the Combo Electrotherapy Device under running water, nor submerge it in water or other liquids.

7.1.3 The Combo Electrotherapy Device is sensitive to heat and may not be exposed to direct sunlight. And do not place it on hot surfaces.

7.1.4 For reasons of hygiene, each user should use his/her own set of electrodes.

7.1.5 Do not use any chemical cleaners or abrasive agents for cleaning.

7.1.6 Ensure that no water penetrates into the machine. Should this happen, use the device again only when it is completely dry.

7.1.7 Do not clean the device during treatment. Be sure that the device is turned off before cleaning.

### **7.2 Maintenance**

7.2.1 The manufacturer didn't authorize any maintenance agencies abroad. If your device has any problems,

please contact the distributor. The manufacturer will not be responsible for the results of maintenance or repairs by unauthorized persons.

7.2.2 The user must not attempt any repairs to the device or any of its accessories. Please contact the retailer for repair.

7.2.3 Opening of the equipment by unauthorized agencies is not allowed and will terminate any claim to warranty.

Each product in manufacturing has been inspected through the systematic validation. The performance is stable and does not need to undertake calibration and validation.

If your product can't reach the expected performance and the basic function has changed in normal use, please contact the retailer.

## **8. TROUBLESHOOTING**

Should any malfunction occur while using the device, check whether the parameters are set appropriately for therapy, and adjust the control correctly. Please see the following table:

Malfunction	Common reasons	Countermeasure
No display after replacing the battery.	<ol style="list-style-type: none"> <li>1. There's foreign body in the battery compartment.</li> <li>2. The battery has been used up or installed oppositely.</li> <li>3. There is foreign body in the battery interface.</li> <li>4. The battery is not the right model or something goes wrong with the battery interface.</li> <li>5. Exception reset.</li> </ol>	<ol style="list-style-type: none"> <li>1. Check and clean the compartment.</li> <li>2. Replace the new battery or install the battery correctly.</li> <li>3. Check and clean the interface.</li> <li>4. Replace the battery with the right model.</li> </ol>
No sensation of stimulation	<ol style="list-style-type: none"> <li>1. The electrode does not connect well to the skin.</li> <li>2. If the connection between electrode connects well to the stimulator.</li> <li>3. The battery is used up.</li> <li>4. The skin is too dry.</li> </ol>	<ol style="list-style-type: none"> <li>1. Check and re-paste it on skin.</li> <li>2. Check the connection.</li> <li>3. Replace the battery.</li> <li>4. Wipe the electrode and the skin with a wet cotton cloth.</li> </ol>
Automatic halt in the treatment	<ol style="list-style-type: none"> <li>1. The electrode loses connection with the skin.</li> <li>2. If the battery is used up.</li> </ol>	<ol style="list-style-type: none"> <li>1. Check and place the electrode properly on the skin.</li> <li>2. Replace the battery.</li> </ol>

<p>Rash or tickle on the skin occurs in treatment</p>	<ol style="list-style-type: none"> <li>1.The treatment time lasts too long.</li> <li>2.The electrode does not stick well to the skin.</li> <li>3. The interface of the electrodes is dirty or dry.</li> <li>4. The skin is sensitive to the electrode.</li> </ol>	<ol style="list-style-type: none"> <li>1. Do the treatment once a day and shorten the treatment time.</li> <li>2. Check and stick the electrode well.</li> <li>3. Wipe the electrode with a wet cotton cloth before use.</li> <li>4. Check your allergic history. Please change the sticking place or shorten the treatment time. If your skin is over-sensitive, you should stop the treatment or go to see a doctor.</li> </ol>
---	---	---

## **9. STORAGE**

### **9.1 Storing The Electrode Pads and Lead Wires**

1. Turn the device off and remove the lead wires from the unit.
2. Remove the electrodes from your body and disconnect the lead wires from the electrodes.
3. Place the electrodes onto the plastic film and then store into the sealed package.
4. Wrap the lead wires and store into the sealed package.

### **9.2 Storing the Unit**

1. Place the unit, electrodes, lead wires and manual back into the carrying case. Store the box in a cool, dry place,

-10°C ~ 55°C ; 10% ~ 90% relative humidity.

2. Do not keep in places that can be easily reached by children.
3. When not in use for a long period, remove the battery before storage.

## **10. DISPOSAL**



Spent batteries do not belong to the household wastes. Disposal of the battery according to the current regulations. As a consumer, you have the obligation to dispose of batteries correctly. Consult your municipal authority or your dealer for information about disposal.

At the end of the product life cycle, do not throw this product into the normal household garbage, but bring it to a collection point for the recycling of electronic equipment. Obsolete electrical and electronic equipment may have potentially harmful effects on the environment. Incorrect disposal can cause toxins to build up in the air, water and soil and jeopardize human health.

## **11. ELECTROMAGNETIC COMPATIBILITY (EMC) TABLES**

Guidance and manufacture's declaration - electromagnetic emissions		
The device is intended for use in the electromagnetic environment specified below. The customer or the user has to assure that it is used in such environment.		
Emissions test	Compliance	Electromagnetic environment - guidance

RF emissions CISPR11	Group 1	The device uses RF energy only for its internal function. Therefore, its RF emissions are very low and are not likely to cause any interference in nearby electronic equipment.
RF emissions CISPR11	Class B	The device is suitable for use in all establishments including those directly connected to the public low-voltage power supply network that supplies to buildings power used for domestic purposes
Harmonic emissions IEC61000-3-2	Not applicable	
Voltage fluctuations/ Flicker emissions IEC61000-3-3	Not applicable	

#### Guidance and manufacture's declaration — electromagnetic immunity

The device is intended for use in the electromagnetic environment specified below. The customer or the user of the device should assure that it is used in such environment.

Immunity test	IEC 60601 Test level	Compliance level	Electromagnetic environment-guidance
Electrostatic discharge (ESD) IEC61000-4-2	$\pm 8\text{kV}$ direct & indirect contact; $\pm 15\text{kV}$ air discharge	$\pm 8\text{kV}$ direct & indirect contact; $\pm 15\text{kV}$ air discharge	Floors should be wood, concrete or ceramic tile. If floors are covered with synthetic material, the relative humidity should be at least 30%
Electrical fast transient/burst IEC 61000-4-4	$\pm 2\text{ kV}$ for power supply lines	not applicable	not applicable (for INTERNALLY POWERED ME EQUIPMENT)

Surge IEC 61000-4-5	$\pm 1$ kV line(s) to line(s)	not applica- ble	not applicable (for INTERNALLY POWERED ME EQUIPMENT)
Voltage dips, short interrup- tions and volt- age variations on power supply input lines IEC 61000-4-11	<5% $U_T$ (>95% dip in $U_T$ ) for 0.5 cycle  40% $U_T$ (60% dip in $U_T$ ) for 5 cycles  70% $U_T$ (30% dip in $U_T$ ) for 25 cycles  <5% $U_T$ (>95% dip in $U_T$ ) for 5 sec	not applica- ble	not applicable (For INTERNAL- LY POWERED ME EQUIPMENT)
Power frequency (50Hz/60Hz) magnetic field IEC 61000-4-8	10V/m	10V/m	Power frequency mag- netic fields should be at levels characteristic of a typical location in typical commercial or hospital environment.

NOTE  $U_T$  is the a.c. mains voltage prior to application of the test level.

Guidance and manufacture's declaration – electromagnetic immunity

The device is intended for use in the electromagnetic environment specified below. The customer or the user of device should assure that it is used in such environment.

Immunity test	IEC 60601 test level	Compliance level	Electromagnetic environment - guidance
Radiated RF IEC 61000-4-3	10V/m & table 9	10V/m & table 9	<p>Portable and mobile RF communications equipment should be used not closer to any part of the device, including cables, than the recommended separation distance calculated from the equation applicable to the frequency of the transmitter. Recommended separation distance</p> <p><math>d = 1.167\sqrt{P}</math> 80 MHz to 800 MHz</p> <p><math>d = 2.333\sqrt{P}</math> 800 MHz to 2.5 GHz</p> <p>Where P is the maximum output power rating of the transmitter in watts (W) according to the transmitter manufacturer and d is the recommended separation distance in meters (m).</p> <p>Field strengths from fixed RF transmitters, as determined by an electromagnetic site survey,<sup>a</sup> should be less than the compliance level in each frequency range.<sup>b</sup> Interference may occur in the vicinity of equipment marked with the following symbol:</p> 
NOTE 1	At 80 MHz and 800 MHz, the higher frequency range applies.		
NOTE 2	These guidelines may not apply in all situations. Electromagnetic propagation is affected by absorption and reflection from structures, objects and people.		

- a Field strengths from fixed transmitters, such as base stations for radio (cellular/cordless) telephones and land mobile radios, amateur radio, AM and FM radio broadcast and TV broadcast cannot be predicted theoretically with accuracy. To assess the electromagnetic environment due to fixed RF transmitters, an electromagnetic site survey should be considered. If the measured field strength in the location in which the device is used exceeds the applicable RF compliance level above, the device should be observed to verify normal operation. If abnormal performance is observed, additional measures may be necessary, such as reorienting or relocating the device.
- b Over the frequency range 150 kHz to 80 MHz, field strengths should be less than [Vi] V/m.

**Test specifications for ENCLOSURE PORT IMMUNITY to RF wireless communications equipment** (Table 9)

















Test frequency (MHz)	Band <sup>a)</sup> (MHz)	Service <sup>a)</sup>	Modulation <sup>b)</sup>	Maximum power (W)	Distance (m)	Immunity Test Level (V/m)
385	380-390	TETRA 400	Pulse modulation <sup>b)</sup> 18Hz	1.8	0.3	27
450	430-470	GMRS 460, FRS 460	FM <sup>c)</sup> ±5kHz deviation 1kHz sine	2	0.3	28
710	704-787	LTE Band 13, 17	Pulse modulation <sup>b)</sup> 217Hz	0.2	0.3	9
745						
780						
810	800-960	GSM800/900, TETRA 800, iDEN 820, CDMA 850, LTE Band 5	Pulse modulation <sup>b)</sup> 18Hz	2	0.3	28
870						
930						

1720	1700-1990	GSM1800; CDMA 1900; GSM 1900; DECT; LTE Band 1,3, 4,25; UMTS	Pulse modulation <sup>b)</sup> 217Hz	2	0.3	28
1845						
1970						
2450	2400-2570	Bluetooth, WLAN, 802.11 b/g/n, RFID 2450, LTE Band 7	Pulse modulation <sup>b)</sup> 217Hz	2	0.3	28
5240	5100-5800	WLAN 802.11 a/n	Pulse modulation <sup>b)</sup> 217Hz	0.2	0.3	9
5500						
5785						

**NOTE** If it is necessary to achieve the IMMUNITY TEST LEVEL, the distance between the transmitting antenna and the ME EQUIPMENT or ME SYSTEM may be reduced to 1 m. The 1 m test distance is permitted by IEC 61000-4-3.

- a) For some services, only the up link frequencies are included.
- b) The carrier shall be modulated using a 50 % duty cycle square wave signal.
- c) As an alternative to FM modulation, 50 % pulse modulation at 18 Hz may be used because it does not represent actual modulation. It would be worst case.

## 12. NORMALIZED SYMBOLS

	WEEE Symbol		Applied part of type BF
	Refer to instruction manual	<b>IP22</b>	IP classification
<b>LOT</b>	Batch code	<b>EC REP</b>	Authorized representative in the European Community
	Manufacturer		Date of manufacture
	Fragile, handle with care		Keep away from sunlight
	Keep dry		Temperature limit
	Use-by date	<b>SN</b>	Serial number
	Humidity limitation		Atmospheric pressure limitation
	Caution		Recycling symbol
	Users of the artificial pacemaker are prohibited from using the device	<b>CE</b> <b>2460</b>	CE mark
	Packaging material cycle mark	<b>MD</b>	Medical device
<b>UDI</b>	Unique device identifier		

## **13. WARRANTY**

Please contact your dealer or the device center in case of a claim under the warranty. If you have to return the unit, enclose a copy of your receipt with clear statement of defect description.

The warranty terms are as below:

1. The warranty period for this device is 1 year from the date of purchase. In case of a warranty claim, the date of purchase has to be proven by means of the sales receipt or invoice.
2. Repairs under warranty should be in the warranty period either for the device or for the replacement parts.
3. The following cases are excluded under the warranty
  - All damages that arise due to improper operation, e.g. nonobservance of the user instruction.
  - All damages due to repairs or tampering by the customer or unauthorized third parties.
  - Damage which have arisen during transport from the manufacturer to the consumer or the service center.
  - Accessories which are subject to normal wear and tear.
  - Device damages due to privately disassembling devices.
4. Liability for direct or indirect consequential losses caused by the unit is excluded even if the damage to the unit is accepted as a warranty claim.





Shenzhen Roundwhale Technology Co., Ltd.

Address: 202, 2/F, Building 27, Dafa Industrial Park,  
longxi community, longgang street, longgang  
district, Shenzhen, China.

E-mail: [info@roovjoy.com](mailto:info@roovjoy.com)



Shanghai International Holding Corp. GmbH(Europe)

Address: Eiffestrasse 80, 20537 Hamburg, Germany

